

SUPER-STICK BUILDING TAPE GUIDE FOR RIGID AIR BARRIER SYSTEMS



Where the SUPER-STICK Building Tape installation is subject to a building consent it should be undertaken or supervised by a Licensed Building Practitioner (LBP).

Preparation

With proprietary Rigid Air Barrier Systems, all exposed timber around the joinery opening must be covered with SUPER-STICK Tape, refer to manufacturers specifications for tape application to joinery openings and sheet joints.

Before any SUPER-STICK is applied, the substrates must be clean and free from any surface contaminants such as dust and grease.

The Rigid Air Barrier must be installed in accordance with the manufacturer's specifications.

Hard rollers must be used to attain adhesion onto all IBS RigidRAP® & Substrates that are not smooth.

1

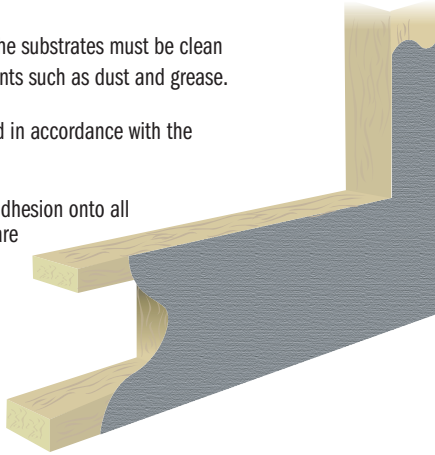

Jamb/Sill Butterfly Application

1. Cut four strips of tape 150mm by 75mm.
2. Apply two strips on the bottom corners at a 45 degree angle and overlapping the corner by 3mm to create a seal at the corner junction.

2

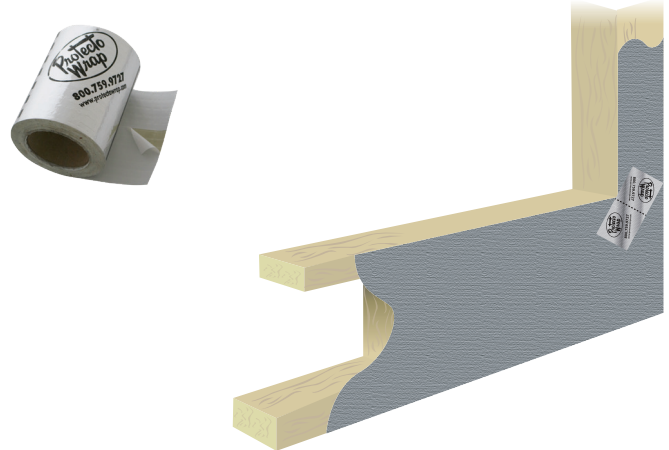

Tape Installation

1. Measure and cut two pieces of SUPER-STICK tape equal to the length of the sill & jamb + 200mm.
2. Mark a line 100mm higher than mid-point up each jamb.
3. Remove 100mm off the release liner on the back of the SUPER-STICK and align with the mark on the jamb.
4. Apply the tape down the jamb, into the sill/jamb junction, across the sill and up the other jamb to the marked line.

3

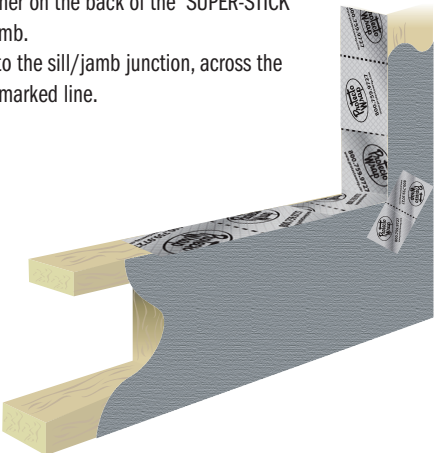

Sill Installation Stage 2

The overhanging tape is cut at the corners of the opening to allow the tape to be folded onto the face of the Rigid Air Barrier & butterfly tapes that are already in place. Peel off the release backing film & fold down & apply to Rigid Air Barrier face & over butterfly tapes.

4

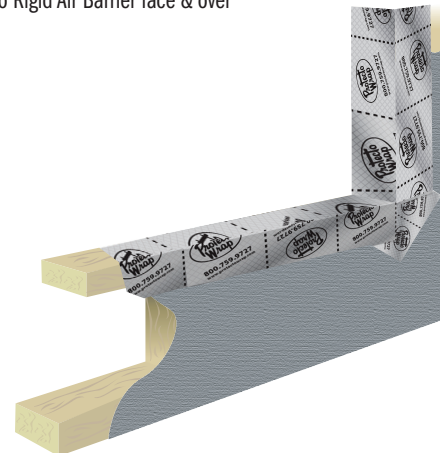

Sill & Nail Sealability

1. Apply a layer of 75mm Super-Stick over the top of the original flashing tape along the entire length of the sill. Align the tape to the outside face of the sill.
2. This is a Building Code requirement for horizontal surfaces to ensure nail sealability. Alternatively 150mm x 150mm pieces of SUPER-STICK may be overlaid to form a double layer where fixings are to be located.

5

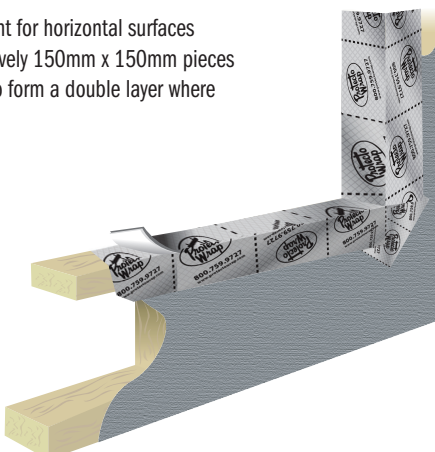

Jamb/Head Application

1. Mark a line 100mm down from the finished edge of the installed SUPER-STICK on each jamb.
2. Remove 100mm of the release liner on the back of the SUPER-STICK and align with the mark on the jamb.
3. Apply the tape up towards the lintel/jamb junction, across the underside of the lintel and down the other jamb to the marked line.
4. The overhanging tape is cut at the corners and folded back onto the face of the Rigid Air Barrier. A 75mm x 150mm butterfly tape is installed at 45 deg across the corner.
 - Ensure the tape is pressed firmly onto substrate to achieve adequate adhesion.
 - Ensure the tape is kept flush with the inside of the frame.
 - Ensure the tape is applied tightly into all corners

6

